

MONITOR DI MINIMA E MASSIMA TENSIONE MONITOR OF MIN AND MAX VOLTAGE

Questo dispositivo monitorizza la minima e la massima tensione di uscita, in corrente continua, fornendo un contatto di allarme per un'eventuale automazione o altro utilizzo.

This device monitoring the minimum and maximum output voltage, in direct current, supplying an alarm contact for an eventual automation or another purpose.

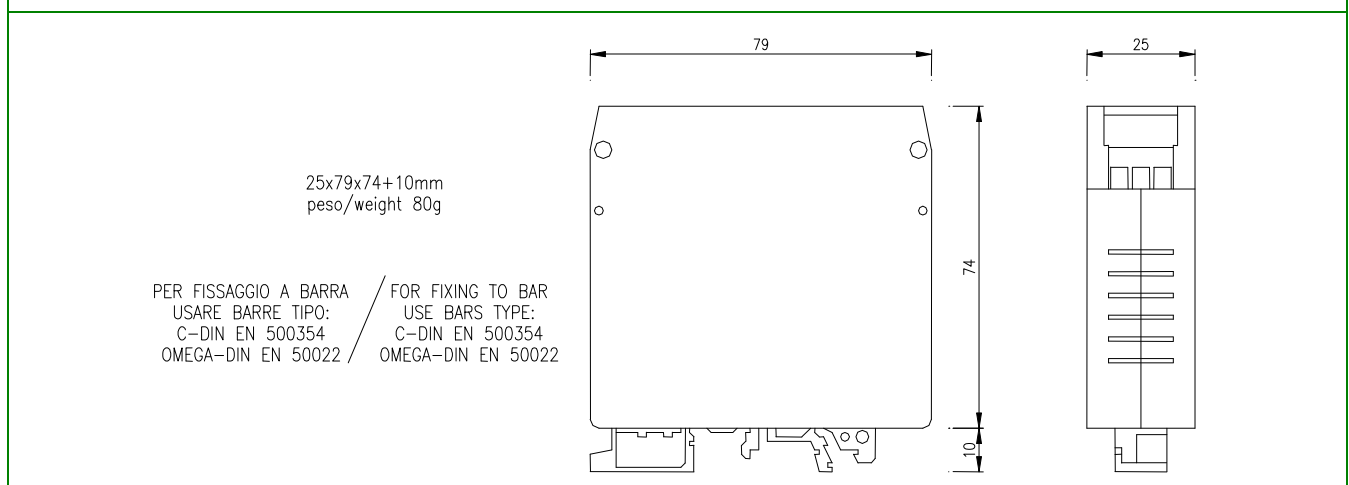
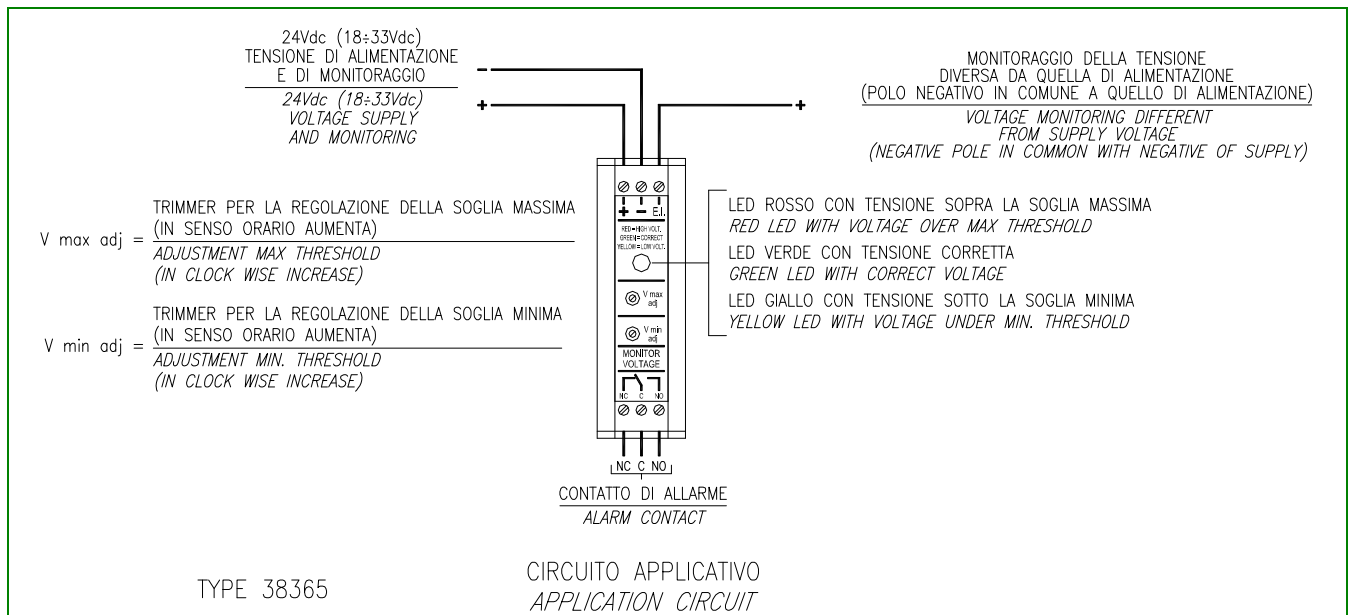

Dati soggetti a modifica senza preavviso / Specification subject to change without notice



SAE
ELECTRONIC
CONVERSION



NTS
GROUP

Lungotorrente Secca, 12/R
tel.+39 010 7261834
info@saepowerelectronic.it

16163 Genova Bolzaneto (Italy)
fax +39 010 7261836
www.sae-elettronica.it